



APPROVAL SHEET

| | |
|--------------------|--|
| PARTS NAME | |
| PARTS NO. | |
| DESCRIPTION | |
| SUPPLIER CODE NO. | |
| DRAWING NO. (REV.) | |
| REFERENCE | |

| DRAWING | CHECK | APPROVAL |
|--------------------|---|----------|
| | | |
| | | |
| A TERM OF VALIDITY | OVER AT LEAST 15-YEARS FROM ISSUED DATE | |





TO :

HUMIDITY SENSOR

P/N : SYH-1 SERIES

=====

SPECIFICATIONS

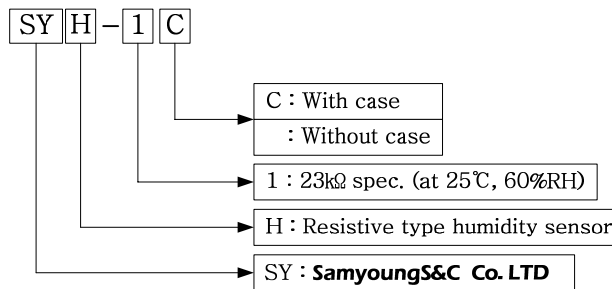
=====



1. Scope of application

This specification is applicable to the resistive type humidity sensor SYH-1 series.

2. Type



2-1. SYH-1 C : Humidity sensor unit with case

2-2. SYH-1 : Humidity sensor unit

3. Configuration

The configuration of the humidity sensor unit is shown on the Fig.1.

4. Electrical characteristics

| | | |
|--------------------------------|---|----------|
| 4-1. Rated voltage | : MAX. AC 5V (recommended 1V _{RMS}) | |
| 4-2. Rated power | : 0.26mW (at 1V _{RMS}) | |
| 4-3. Standard characteristic | : 23kΩ (at 25°C, 60%RH, 1V _{RMS} , 1kHz) | [Fig. 2] |
| 4-4. Operating temperature | : 0 ~ 60°C | [Fig. 3] |
| 4-5. Operating humidity range | : 20 ~ 90%RH (non-condensing) | |
| 4-6. Operating frequency range | : 100Hz ~ 10kHz | [Fig. 4] |
| 4-7. Storage temperature range | : -30 ~ 85°C | |
| 4-8. Storage humidity range | : Less than 95%RH (non-condensing) | |
| 4-9. Accuracy | : ±5%RH (at 25°C, 60%RH) | |
| 4-10. Hysteresis | : Within 2%RH (at 25°C, 40⇔80%RH) | |
| 4-11. Response time | : Less than 60 sec. (40⇔80%RH) | |
| 4-12. Temperature coefficient | : - 0.5%RH / °C | |



5. Reliability

| No | Test Item | Test Condition | Test Criterion |
|----|--|--|----------------|
| 1 | High Temperature Storage | - Temperature: 85℃, Test time : 1,000 hours Recovery time : 1 ~ 2 hours | < ± 5%RH |
| 2 | Low Temperature Storage | - Temperature : - 30℃, Test time : 1,000 hours. Recovery time : 1 ~ 2 hours | < ± 5%RH |
| 3 | High Temperature/High Humidity Loading | - Temperature : 40 ℃, Humidity : 95 %RH Test time : 1000 hours, Bias : 1V _{pp} , 1kHz Recovery time : 1 ~ 2 hours | < ± 5%RH |
| 4 | Humidity cycle | - Temperature : 25 ℃, Cycle : 500 times Humidity : 30(30min)↔90(30min) %RH Recovery time : 1 ~ 2 hours | < ± 5%RH |
| 5 | Temperature cycle (Thermal-shock test) | - Temperature : -30(30min)↔85(30min)℃ Cycle : 100 times Recovery time : 1 ~ 2 hours | < ± 5%RH |
| 6 | Organic solvent resistance | - Benzene 30wt.%+ Xylene 40wt.% + Toluene 30wt.%. Temperature: 25℃, Test time : 300 hours Recovery time : 1 ~ 2 hours | < ± 5%RH |
| 7 | Voltage resistance | - Impress 1V _{RMS} , 1kHz, Test time : 3,000 hours. Recovery time : 1 ~ 2 hours | < ± 5%RH |

6. Mechanical characteristics

6-1. Shock resistance

Not to be abnormal in the appearance and electrical characteristics after having been naturally let to drop down 3 times at random onto a hard wooden plate from the height of 100cm.

6-2. Vibration resistance

Not to be abnormal in the appearance and electrical characteristics after having been vibration-tested for 2 hours each in the directions of X-Y-Z, at the frequency of 10~55Hz, and amplitude of 1.5mm (10-55-10).

6-3. Resistance to soldering heat

Not to be abnormal in the appearance and electrical characteristics after lead terminal shall be immersed down by 3mm from the substrate for 3 seconds in a solder bath of 260±5℃.



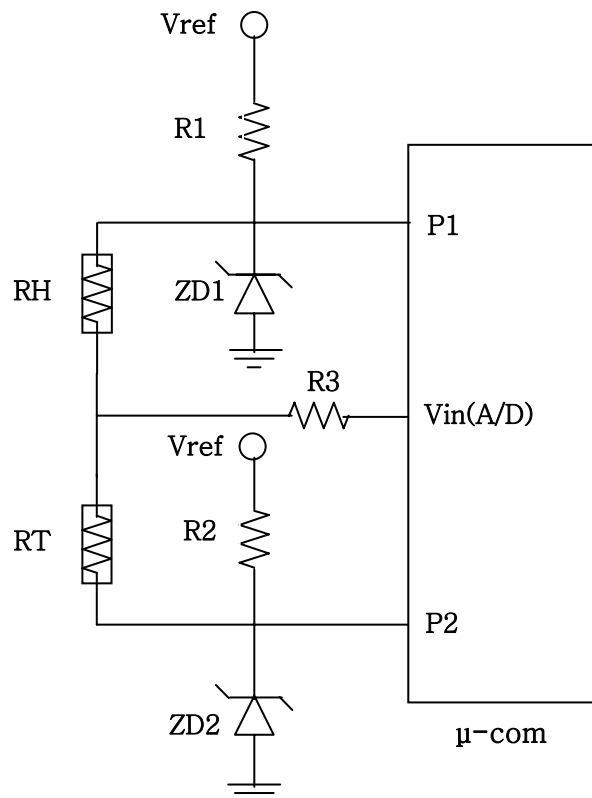
6-4. Strength of terminations(tensile)

Lead terminal shall be secured by the body after it shall be pulled with the specified force of 500g for 10 seconds in the axial direction of lead terminal.

7. Packaging : [Fig. 5.]

- 7-1. 50pcs of sensor unit to be packed in a tray (PET, SYH-1)
- 7-2. 20 sheet (1000pcs of sensor unit) to be packed in a shipping carton box (SYH-1, size : 200×145×75mm)
- 7-3. 100pcs of sensor unit to be packed in a vinyl pack (SYH-1 C)
- 7-4. 10 set (1000pcs of sensor unit) to be packed in a shipping carton box (SYH-1 C, size : 280×280×55mm)

8. Basic circuits (example)



Positive Output : $V_{in} = RT/(RT+ RH) * V_{zd}$

Negative Output : $V_{in} = RH/(RH+ RT) * V_{zd}$

Zener Diode ZD1, ZD2 : 2.2V to 4.7V

RH : Humidity Sensor(SYH-1 or SYH-2 series)

RT : $R(25^{\circ}C) = 50k\Omega$, $B(25/85^{\circ}C)=4600$



9. Measuring systems

| | | | |
|-----------|------------------------------|------------|-----------|
| LCR meter | HIOKI | Hygrometer | E+ E EE31 |
| Chamber | ESPEC (Accu. $\pm 2.5\%RH$) | | |

10. Remark on using (Using attention)

10-1. DC voltage

If DC voltage will be applied to the humidity sensor, **the migration phenomenon** will occur in the sensor. The migration effect become resistance quality defective and cause of short circuit (polarization phenomenon)

10-2 Water condensing

If the water(water-drop, moisture.. etc) will be **condensed on the humidity sensor surface**, the sensor membrane will be melt in the water. It become resistance quality defective.

10-3 Drenching (water, solvent .. etc.)

If the humidity sensor will be **soaked in the liquid material** (water, solvent .. etc), the sensor membrane will be melt in the water. It become resistance quality defective.

10-4 Ionic atmosphere

SYH series humidity sensor is made by using ionic polymer membrane. Therefore if the humidity sensor will be exposed **ionic atmosphere**(salty air, anionic ionizer.. etc) for a long time, **the resistance-drop characteristics** will occur in the sensor

10-5 Organic / Inorganic gas

If the humidity sensor will be exposed **organic / inorganic gases** for a long time that have reactive polymer membrane, the sensor (humidity sensitive) membrane will be damaged. It become resistance quality defective.

(For example : SO_x, NO_x, Ammonia, Alcohol, Glycol .. etc.)

10-6 Breakdown / Scrach / Membrane touching

If the humidity sensor will be received physical external pressure such as **breakdown of sensor substrate, sensor scrach, touching sensor membrane**, the sensor (humidity sensitive) membrane and electrode will be damaged. It become resistance quality defective.

10-7 Heating stress (thermal shock)

In relation to **heating stress**, take extra caution using in the atmosphere of the below

- 1) Using the humidity sensor at over-range temperature
- 2) Failed circuit design
- 3) PCB soldering process

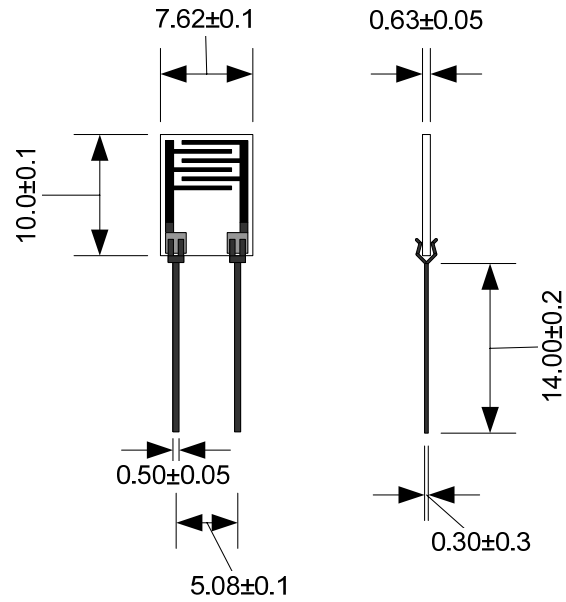
10-8 Soldering process

Protect the sensor element from flux/fume and high temperature during the soldering

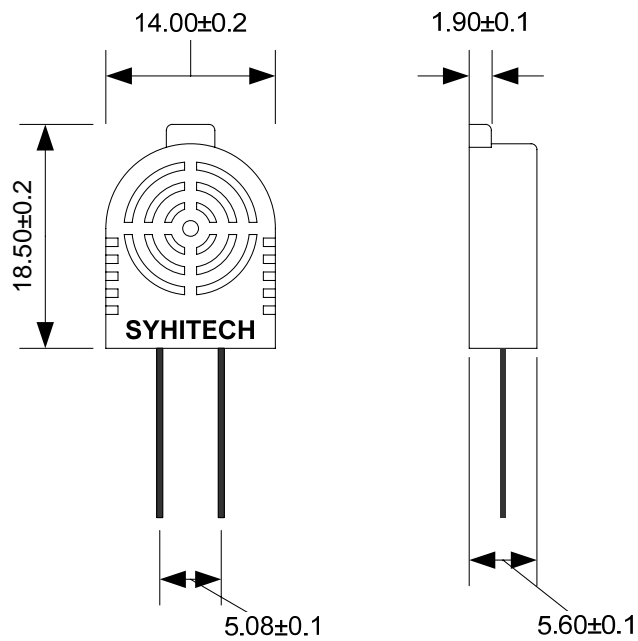


Fig. 1. Standard Dimension SYH-1 series

(unit : mm)



< SYH-1 >



< SYH-1 C >

Fig. 2. Standard characteristics

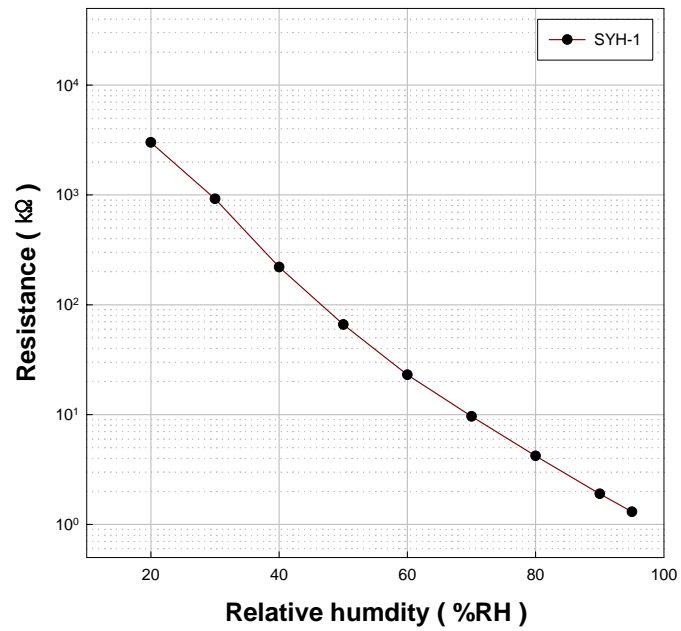


Fig. 3. Temperature characteristics

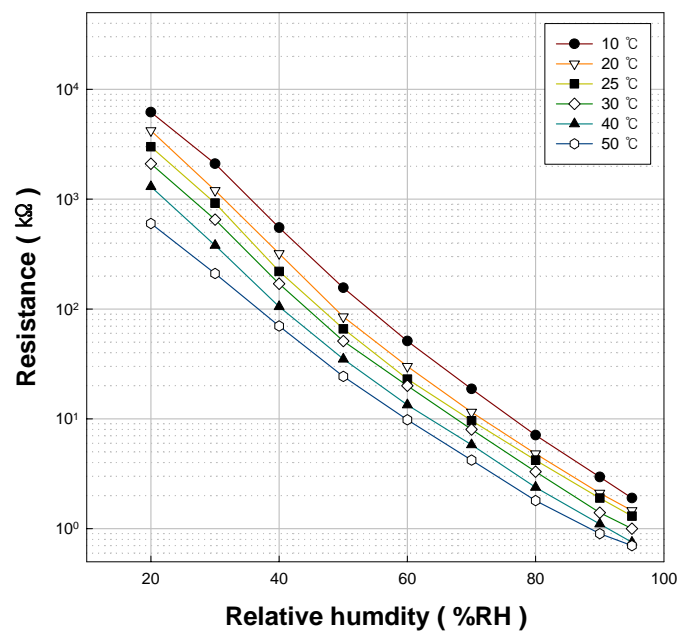


Fig. 4. Frequency characteristics

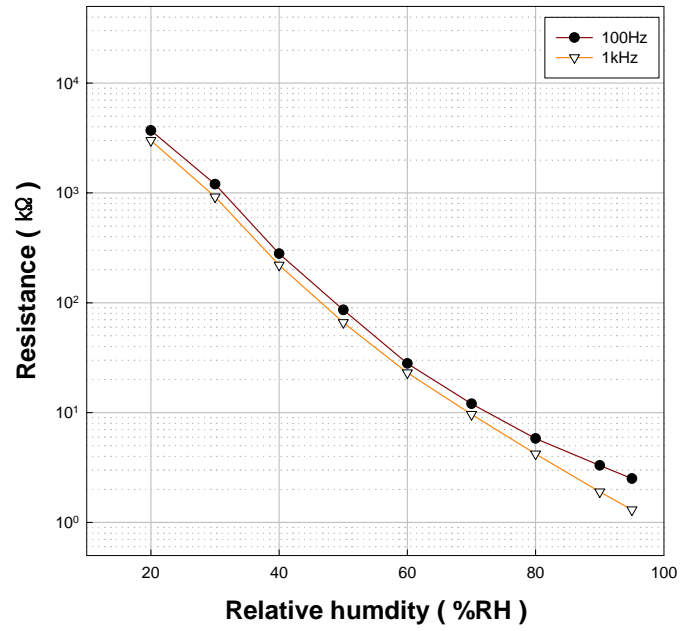
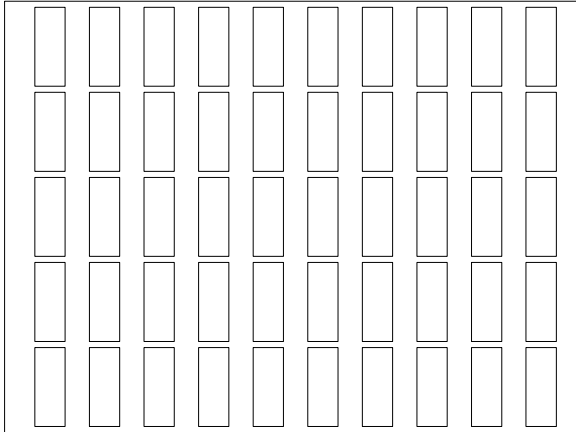
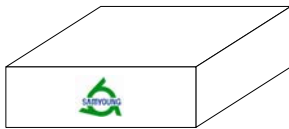


Fig. 5. Packaging

Tray (PET, 190×140×6 mm)



Inlet box (without case : 200×145×75 mm, with case : 280×280×55mm)



Outlet box(650×360×310 mm)

